

QSI LASER DIODE SPECIFICATIONS FOR APPROVAL

Customer :

Model : QL78C7PB

Signature of Approval

Approved by _____

Checked by _____

Issued by _____

Approval by Customer



QSI Co., Ltd.

**315-9, Cheonheung-ri, Sungger-eup,
Cheonan-city, Chungnam, Korea 330-836**

WWW.QSILaser.com

QL78C7PB

AlGaAs Laser Diode

Quantum Semiconductor International Co., Ltd.

Ver.02 2008-10-01

◆ OVERVIEW

QL78C7PB is a MOCVD grown 780nm band AlGaAs laser diode with multi quantum well structure. It's an attractive light source, with a typical light output power of 3mW for industrial optical pick up and sensor application.

◆ APPLICATION

- CD, CD-ROM

◆ FEATURES

- Visible Light Output : $\lambda_p = 780 \text{ nm}$
- Optical Power Output : 3mW CW
- Package Type : Lead Frame
- Built-in Photo Diode for Monitoring Laser Diode

◆ ELECTRICAL CONNECTION

Pin Configuration

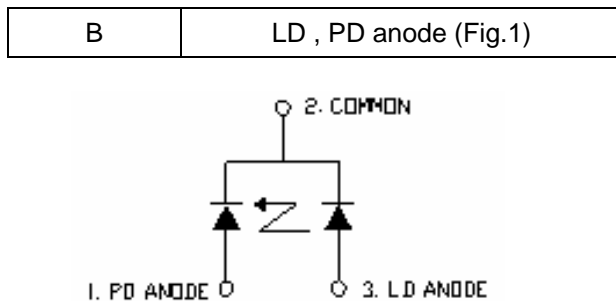

Fig. 1
QL78C7PB

◆ ABSOLUTE MAXIMUM RATING at Tc=25°C

Item	Symbols	Values	Unit
Optical Output Power	P	4.5	mW
Laser Diode Reverse Voltage	V	2	V
Photo Diode Reverse Voltage	V	30	V
Operating Temperature	Topr	-10 ~ +70	°C
Storage Temperature	Tstg	-40 ~ +85	°C

◆ ELECTRICAL and OPTICAL CHARACTERISTICS at Tc=25°C

Items	Symbols	Min.	Typ.	Max.	Unit	Condition
Optical Output Power	Po	-	3	-	mW	-
Threshold Current	Ith	-	25	40	mA	-
Operating Current	Iop	-	30	50	mA	Po=3mW
Operating Voltage	Vop	-	1.9	2.3	V	Po=3mW
Slope Efficiency	SE	0.3	0.5	0.7	mW/mA	2mW/I(3mW)-I(1mW)
Lasing Wavelength	λ_p	770	785	810	nm	Po=3mW
Beam Divergence	$\theta_{ }$	8	12	16	deg	Po=3mW
	θ_{\perp}	20	33	45	deg	
Beam Angle	$\Delta\theta_{ }$	-	-	±3.0	deg	Po=3mW
	$\Delta\theta_{\perp}$	-	-	±3.6	deg	
Monitor Current	I _m	0.09	0.15	0.6	mA	Po=3mW
Optical Distance	$\Delta X, \Delta Y, \Delta Z$	-	-	± 100	μm	Po=3mW

NOTICE : QL78C7PB to be operated on APC circuit.

The above product specifications are subject to change without notice.

◆ PACKAGE DIMENSION

Unit : mm

